

• General Description

It combines advanced trench MOSFET technology with a low resistance package to provide extremely low $R_{DS(ON)}$. This device is ideal for load switch and battery protection applications.

• Features

- Advance high cell density Trench technology
- Low $R_{DS(ON)}$ to minimize conductive loss
- Low Gate Charge for fast switching
- Low Thermal resistance

• Application

- SMPS 2nd Synchronous Rectifier
- BLDC Motor driver

• Product Summary

$V_{DS} = 60V$

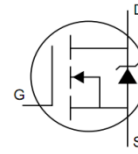

$R_{DS(ON)} = 50m\Omega$

$I_D = 9A$

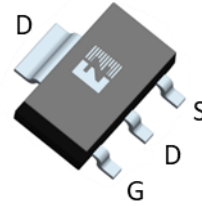

SOT-223

• Ordering Information:

Part NO.	ZM500N06E
Marking	500N06
Packing Information	REEL TAPE
Basic ordering unit (pcs)	3000

• Absolute Maximum Ratings ($T_c = 25^\circ C$)

Parameter	Symbol	Rating	Unit
Drain-Source Voltage	V_{DS}	60	V
Gate-Source Voltage	V_{GS}	± 20	V
Continuous Drain Current	$I_D @ T_C = 25^\circ C$	9.0	A
	$I_D @ T_C = 75^\circ C$	6.8	A
	$I_D @ T_C = 100^\circ C$	5.6	A
Pulsed Drain Current ^①	I_{DM}	27	A
Total Power Dissipation	$P_D @ T_C = 25^\circ C$	8	W
Total Power Dissipation ^②	$P_D @ T_A = 25^\circ C$	1	W
Operating Junction Temperature	T_J	-55 to 150	$^\circ C$
Storage Temperature	T_{STG}	-55 to 150	$^\circ C$
Single Pulse Avalanche Energy @ $L = 0.1mH$	E_{AS}	10	mJ
ESD Level (HBM)		CLASS 1B	

•Thermal resistance

Parameter	Symbol	Min.	Typ.	Max.	Unit
Thermal resistance, junction - case ^②	R _{thJC}	-	-	15	° C/W
Thermal resistance, junction - ambient	R _{thJA}	-	-	120	° C/W
Soldering temperature, wavesoldering for 10s	T _{sold}	-	-	265	° C

•Electronic Characteristics

Parameter	Symbol	Condition	Min.	Typ	Max.	Unit
Drain-Source Breakdown Voltage	BV _{DSS}	V _{GS} = 0V, I _D = -250uA	60			V
Gate Threshold Voltage	V _{GS(TH)}	V _{GS} = V _{DS} , I _D = 250uA	1.2		2.5	V
Drain-Source Leakage Current	I _{DSS}	V _{DS} = 60V, V _{GS} = 0V			1.0	uA
Gate- Source Leakage Current	I _{GSS}	V _{GS} = ±20V, V _{DS} = 0V			±100	nA
Static Drain-source On Resistance	R _{DS(ON)}	V _{GS} = 10V, I _D = 8A		50	65	mΩ
		V _{GS} = 4.5V, I _D = 6A		62	85	mΩ
Forward Transconductance	g _{FS}	V _{DS} = 10V, I _D = 5A		4		s
Source-drain voltage	V _{SD}	I _S = 8A			1.28	V

•Electronic Characteristics

Parameter	Symbol	Condition	Min.	Typ	Max.	Unit
Gate Resistance	R _g	f = 1MHz		1.9		Ω
Input capacitance	C _{iss}	V _{GS} = 0V, V _{DS} = 25V f = 1MHz	-	823	-	pF
Output capacitance	C _{oss}		-	33	-	
Reverse transfer capacitance	C _{rss}		-	19	-	

•Gate Charge characteristics(T_a = 25°C)

Parameter	Symbol	Condition	Min.	Typ	Max.	Unit
Total gate charge	Q _g	V _{DD} = 25V	-	11	-	nC
Gate - Source charge	Q _{gs}	I _D = 8A	-	2.5	-	
Gate - Drain charge	Q _{gd}	V _{GS} = 10V	-	1.5	-	

Fig.1 Gate-Charge Characteristics

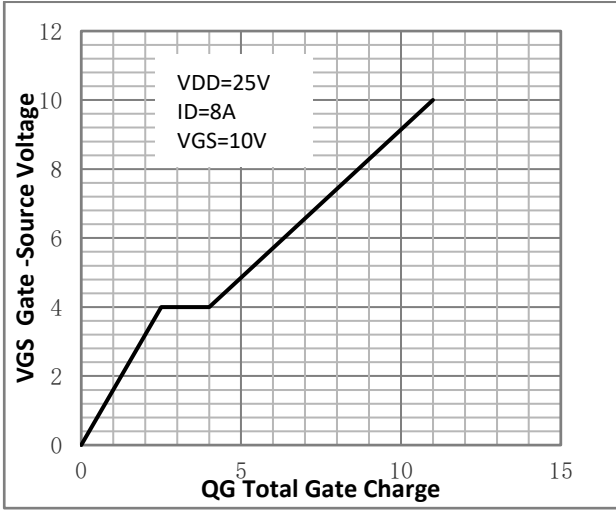

Fig.2 Capacitance Characteristics

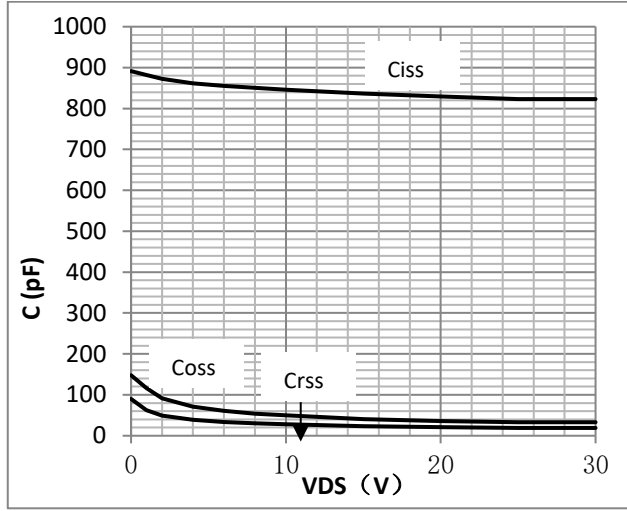

Fig.3 Power Dissipation Derating Curve

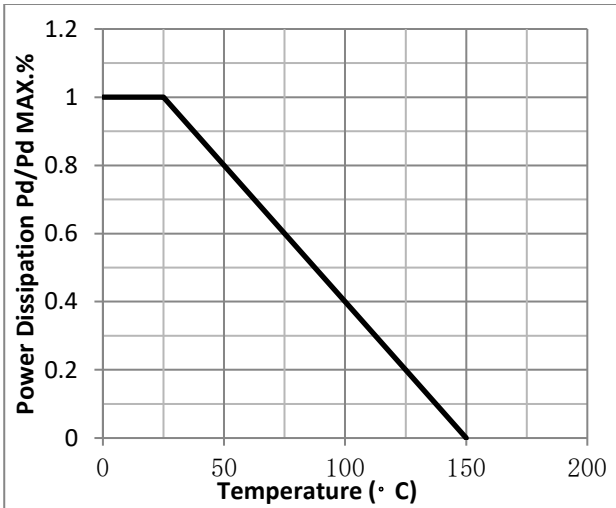

Fig.2 Typical output Characteristics

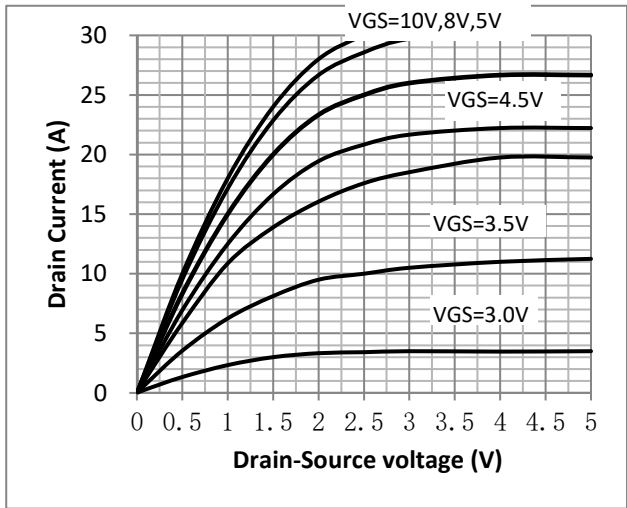

Fig.3 Threshold Voltage V.S Junction Temperature

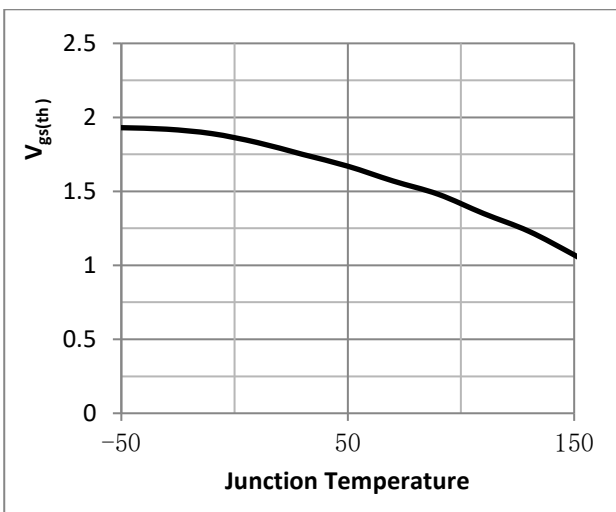

Fig.4 Resistance V.S Drain Current

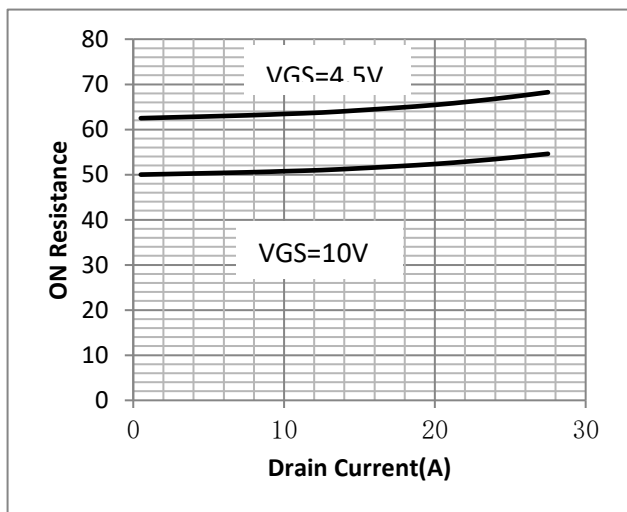

Fig.5 On-Resistance VS Gate Source Voltage

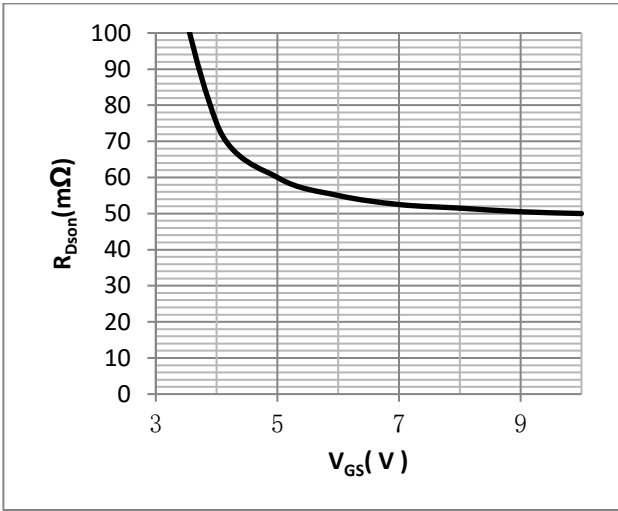

Fig.6 On-Resistance V.S Junction Temperature

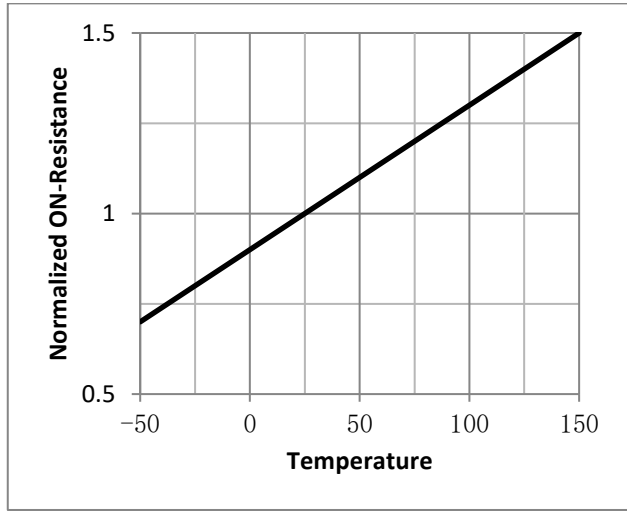

Fig.9 SOA Maximum Safe Operating Area

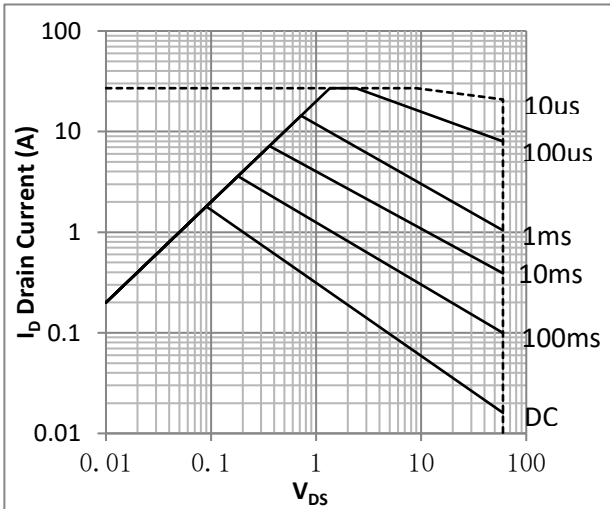

Fig.10 I_D -Junction Temperature

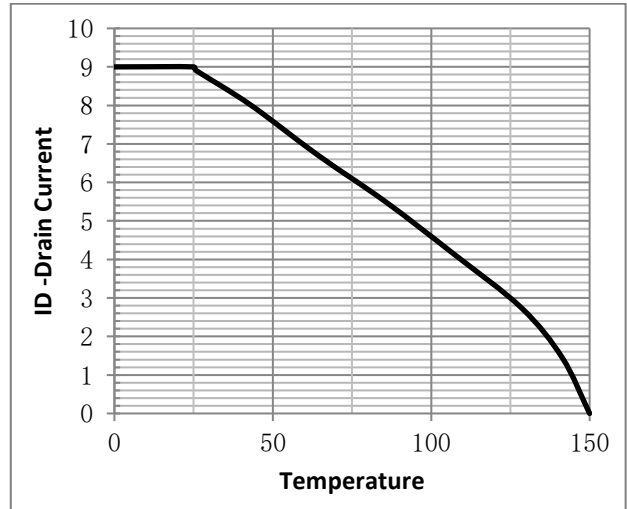

Figure 11. Diode Forward Voltage vs. Current

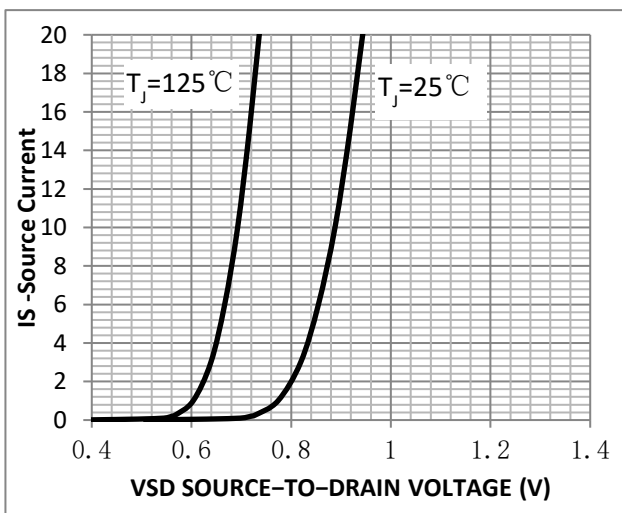

Figure 12. Transfer Characteristics

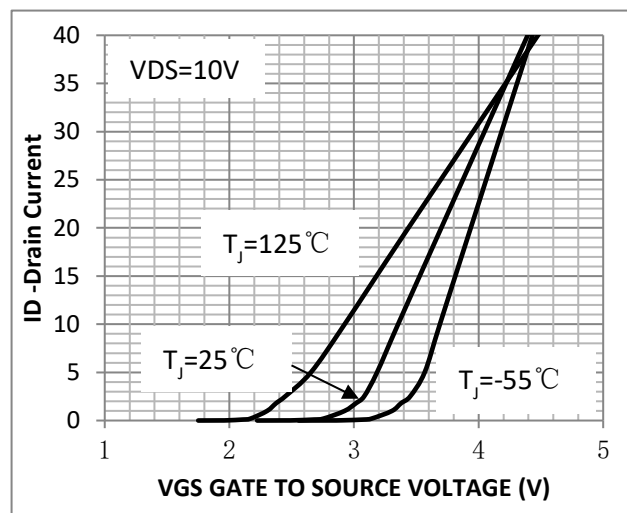

Fig.7 Gate Charge Measurement Circuit

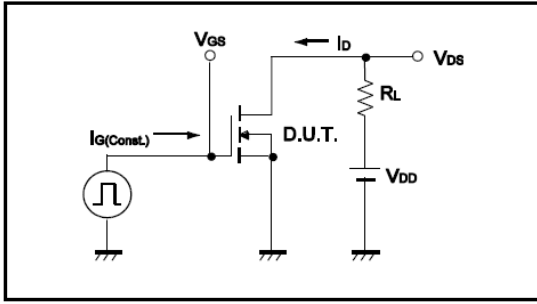

Fig.8 Gate Charge Waveform

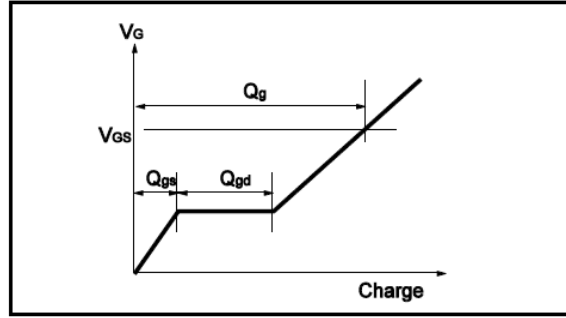

Fig.9 Switching Time Measurement Circuit

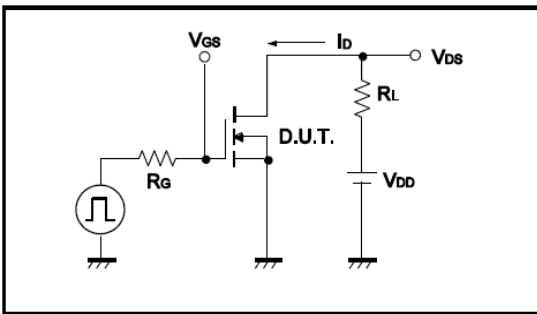

Fig.10 Switching Time Waveform

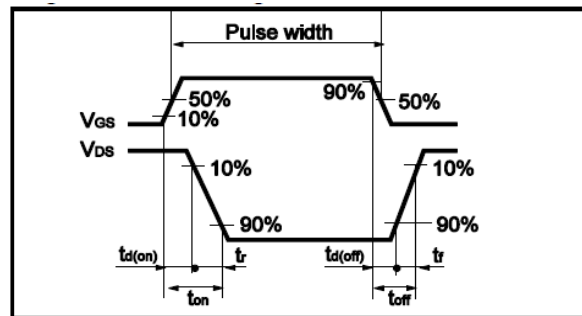

Fig.11 Avalanche Measurement Circuit

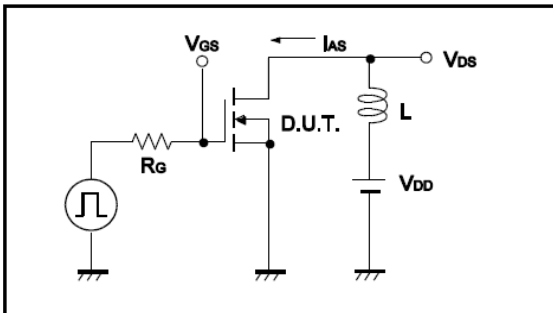
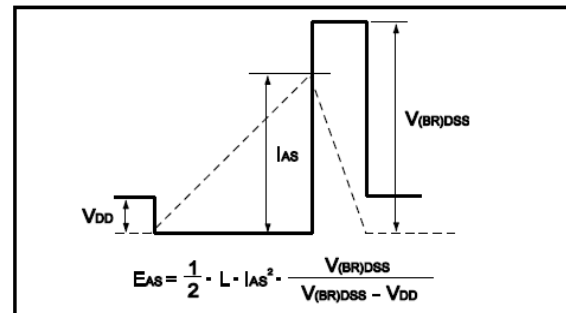
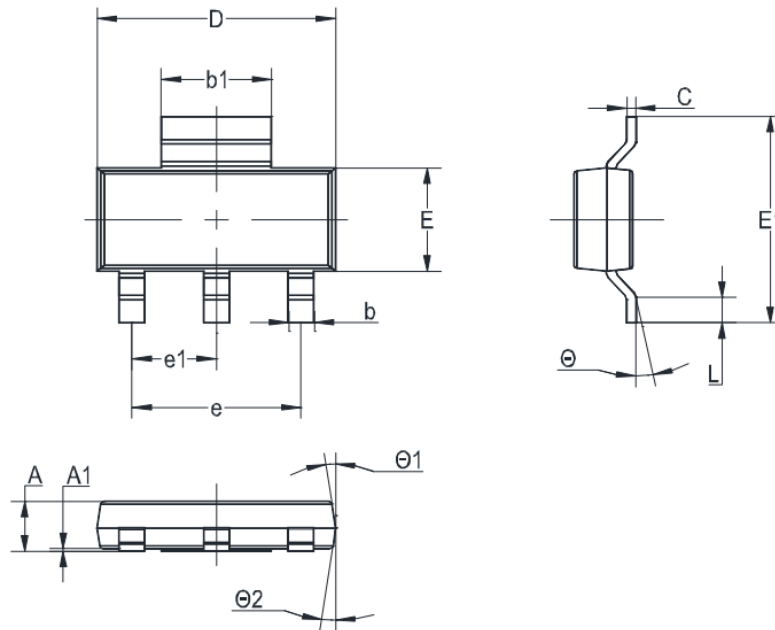

Fig.12 Avalanche Waveform



•Dimensions(SOT-223)

Unit: mm



Unit	A	A1	b	b1	C	D	E	E1	e	e1	L	Θ	Θ1	Θ2
mm	1.8	0.1	0.8	3.1	0.32	6.7	3.7	7.3	4.6	2.3	1.1	10°	7°	7°
	1.5	MAX	0.6	2.9	0.22	6.3	3.3	6.7	TYP	TYP	0.7	0°	0°	0°

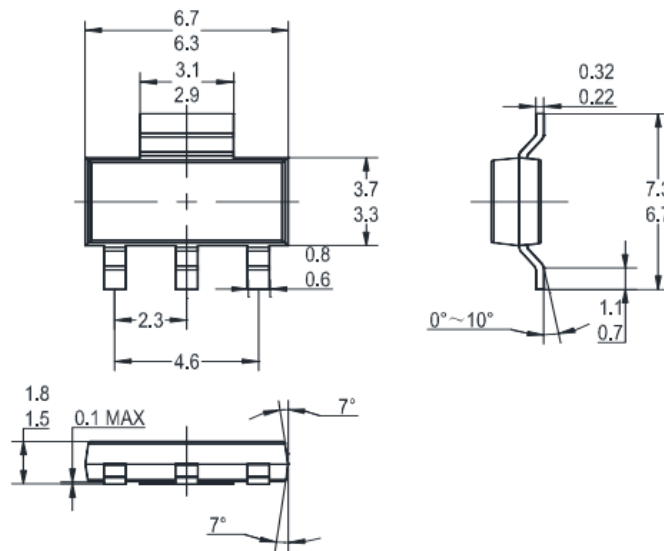



Recommended Soldering Footprint

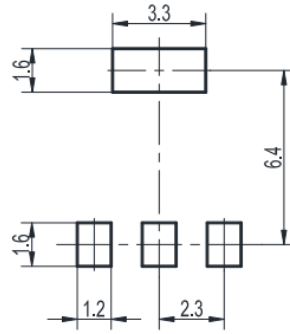

Packing information

Package	Tape Width (mm)	Pitch		Reel Size		Per Reel Packing Quantity
		mm	inch	mm	inch	
SOT-223	12	8 ± 0.1	0.315 ± 0.004	330	13	3,000



Note: ① Pulse Test: Pulse width $\leq 300\mu\text{s}$, Duty cycle $\leq 2\%$;

② Device mounted on FR-4 substrate PC board, 2oz copper, with thermal bias to bottom layer 1inch square copper plate;

Disclaimer

- Reproducing and modifying information of the document is prohibited without permission from ZMJ SEMICONDDUCTORS CO.,LTD.
- ZMJ SEMICONDDUCTORS CO.,LTD. reserves the rights to make changes of the content herein the document anytime without notification. Please refer to our website for the latest document.
- ZMJ SEMICONDDUCTORS CO.,LTD. disclaims any and all liability arising out of the application or use of any product including damages incidentally and consequentially occurred.
- ZMJ SEMICONDDUCTORS CO.,LTD. does not assume any and all implied warranties, including warranties of fitness for particular purpose, non-infringement and merchantability.
- Applications shown on the herein document are examples of standard use and operation. Customers are responsible in comprehending the suitable use in particular applications. ZMJ SEMICONDDUCTORS CO.,LTD. makes no representation or warranty that such applications will be suitable for the specified use without further testing or modification.
- The products shown herein are not designed and authorized for equipments relating to human life and for any applications concerning life-saving or life-sustaining, such as medical instruments, aerospace machinery et cetera. Customers using or selling these products for use in such applications do so at their own risk and agree to fully indemnify ZMJ SEMICONDDUCTORS CO.,LTD. for any damages resulting from such improper use or sale.
- Since ZMJ uses lot number as the tracking base, please provide the lot number for tracking when complaining.